

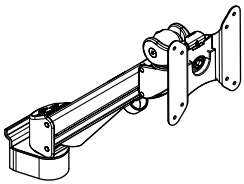







Monitor Arm LC55 for Conceptum
 In order to achieve a correct mounting of Monitor Arm LC55, you are advised to read and follow the instructions step by step. If there are incomprehensible steps, please let us know and we will get back to you.



Part Check-List

STEP 1

- ①A  x1
- ②A  x2
- ②B  x2
- ③A  x2
- ③B  x2

- ④  x1
- ⑤  x1
- ⑥  x1

STEP 2

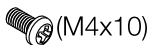
- ⑦A  x4
- ⑦B  x4
- ⑧  x4
- ⑨  x1

STEP 1

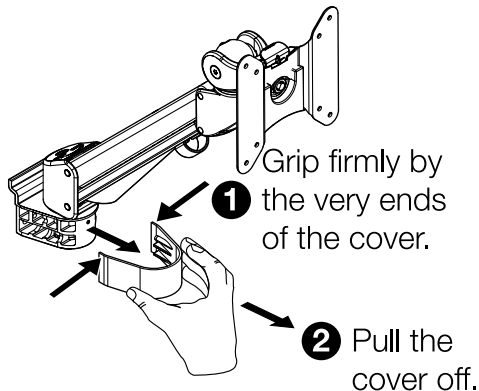

③ Hook the bracket into the track of your compatible aluminum profile. See next step for further guidance.

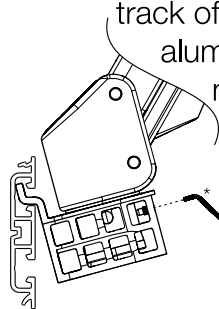

*If the profile is integrated into the table screen, you might have to separate the arm from the bracket. In that case, use the Allen key (2 mm) provided.

Conceptum M-Profile 436-MX

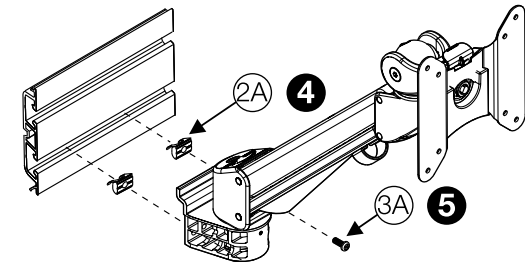

F-Profile 436-FX100

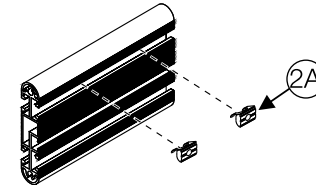
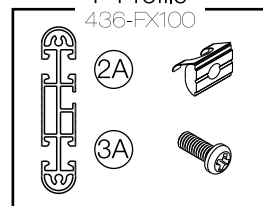

Identify the correct nuts and screws using the boxes. Then, fixate the monitor arms to the desired position on the aluminum profile.

Other possible assemblies

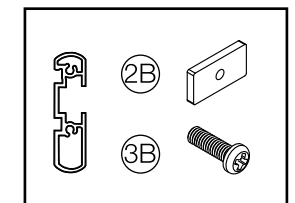
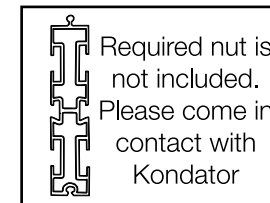
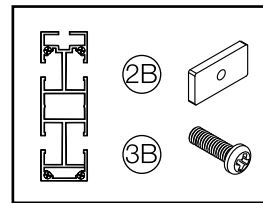

Insert the nut with the blocky side towards yourself and the rounded side towards the aluminum profile for best grip (as illustrated to the left). Once inserted, make sure to center and align the components before fastening the screws (as illustrated to the right).

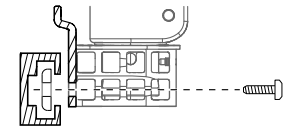

STEP 2

Remove the VESA plate by pinching the grey plastic tab to release the lock, then pull the VESA plate upwards to separate it from the arm.

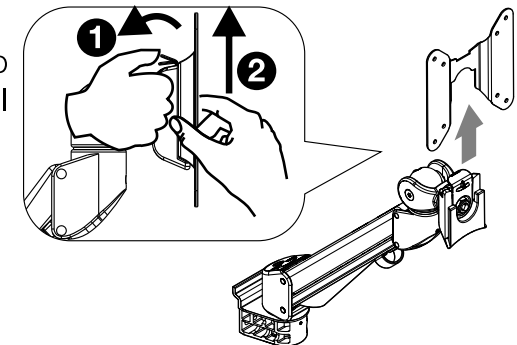

Assembly Guide

STEP 3

Place the monitor face down on a flat surface. Align the VESA plate holes with the holes on the back of the monitor. Attach using the correct screws for the desired monitor.

If the VESA mount fits with the monitor, proceed with the usage of (7A). In case it does not, assembly using the long screws (7B) and distance nuts (8). Secure the assembly with a screwdriver (not provided).

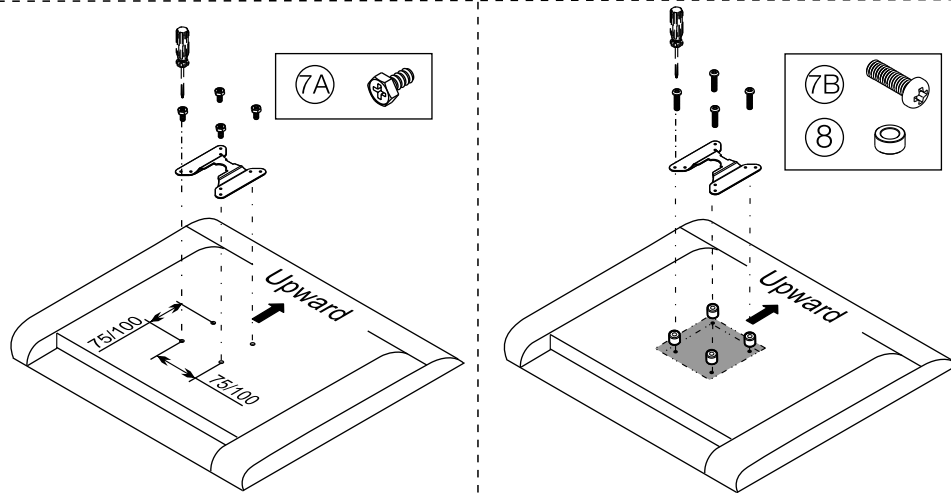
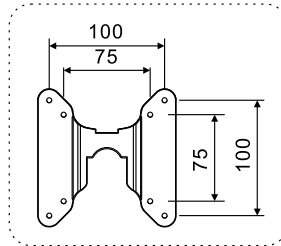

STEP 4

Slide the monitor (with VESA plate) onto the arm and make sure it "clicks" securely into position.

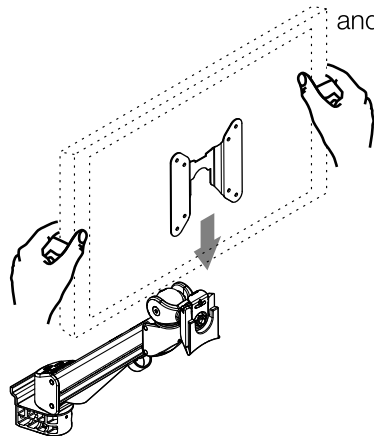

Use screwdriver to secure the screw.

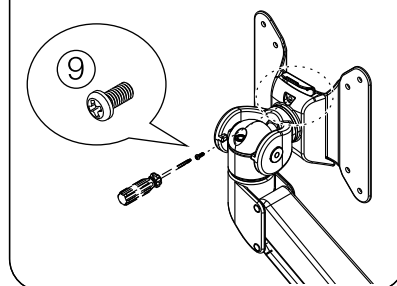

www.kondator.se

Assembly Guide

STEP 5

Unattach the small cable collector and route the cables through. Once satisfied, re-attach the collector back into place, and cover the bottom bracket.

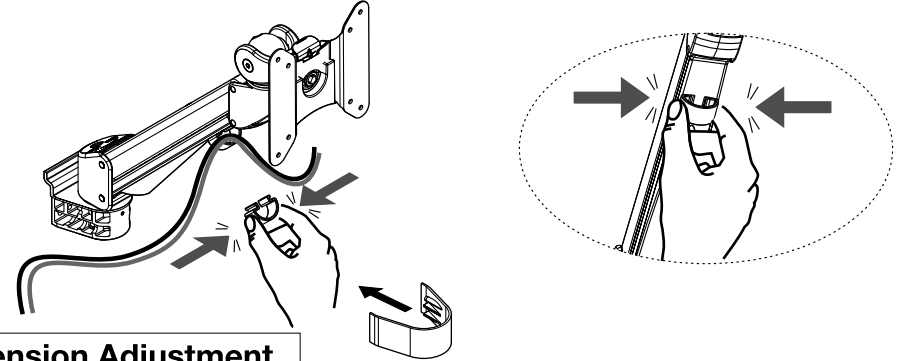

Tension Adjustment

Caution:

Support and hold on to the arm while adjusting the tension.

Adjustment:

Use the Allen key provided to adjust the tension to correspond to the weight of the desired monitor. Turn the Allen key (4) counter-clockwise to adjust for heavier monitors; clockwise for lighter monitors. Once the adjustment is done, the monitor should be experienced as weightless and the monitor should remain in any position without dropping nor rising.

Recommendations:

- 3-8 kg (6.6-17.6 lbs).
- The products loading capacities are based on monitors' center of gravity less than 3 cm from the end of the VESA interface.
- Loading capacity could be reduced if the monitor size is greater than 26 inches or if the thickness exceeds 5.5 cm.
- All product specifications in catalogues are subject to change without notice.

When the joint loosens, use Allen key (5) to tighten the joint. Clockwise to tighten for heavier monitors; Counter-clockwise to loosen.

